

MUGNAINI®

MODEL: 120 PA COMMERCIAL BUILT IN ENCLOSURE

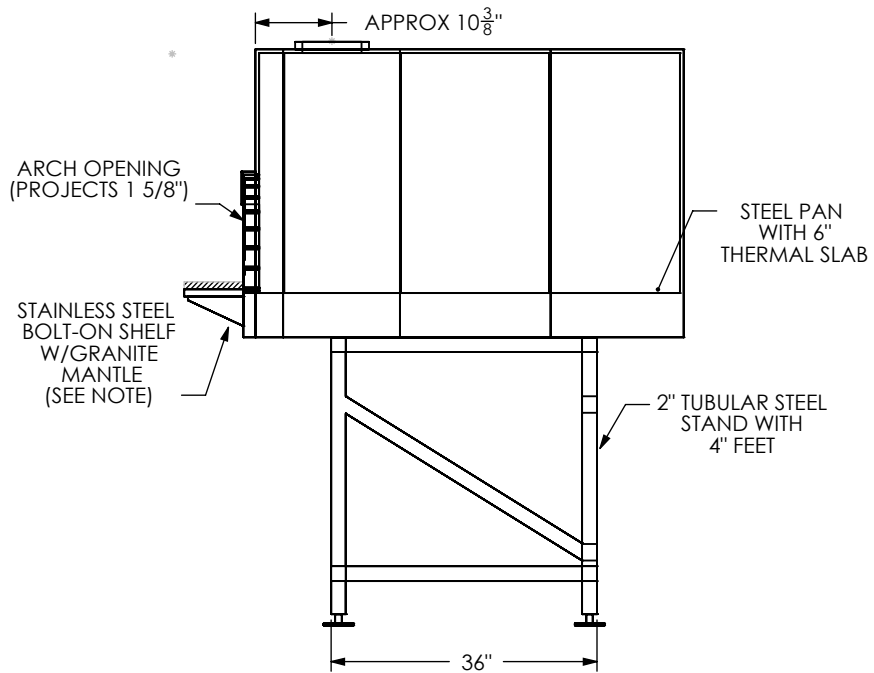

20 GAUGE GALVANIZED STEEL SURROUND WITH 1/2" CEMENT BOARD FRONT PANEL

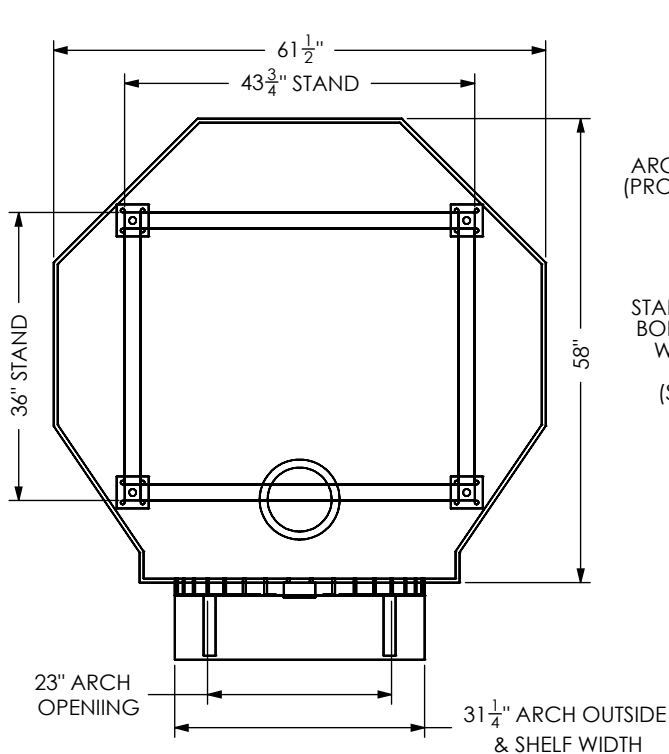
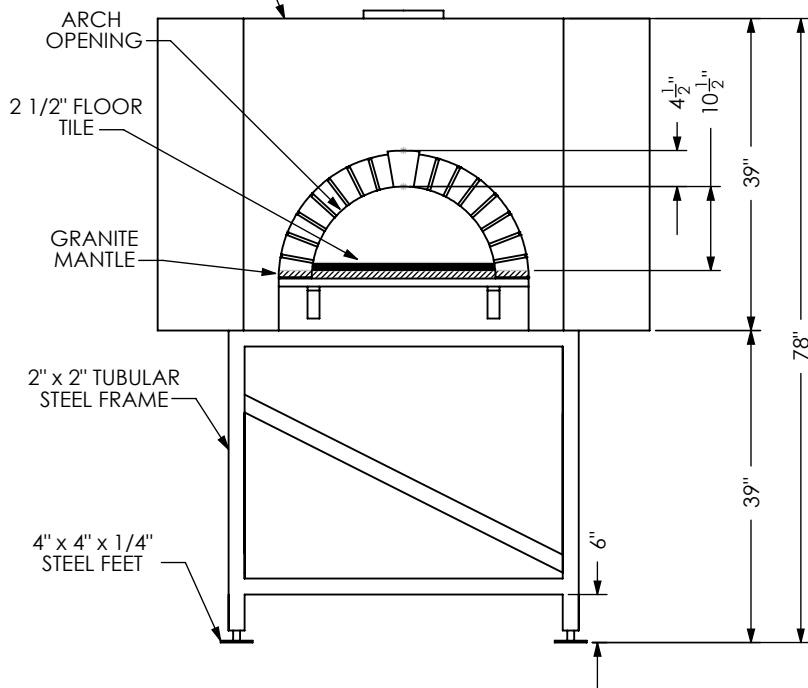

NOTES:

CLEARANCES

The oven shall be installed a minimum of 2" away from combustilbe material from back wall to oven and side wall to oven. You may bridge the gap between any wood framing and the oven by using metal framing with concrete board or masonry.

VENTING

The oven can be vented in two methods:
1- Direct vent using 8" chimney pipe listed to UL 103 HT and installed per UL 737.
2- Indirect vent using a Type 1 hood system installed per UL 2162

GRANITE MANTLE

Stainless steel shelf bolts to oven. 1" thick granite provided by installer. A custom shelf may be provided by others.

UTILITIES

No electricity or gas required.

LISTINGS

Mugnaini Wood-fired Ovens have been tested and comply with the UL 737, UL 2162 and NSF-4 by ETL Semko.

Progressive changes in technology and product development may necessitate changes to specifications without notice.

DRAWINGS NOT TO SCALE



MUGNAINI IMPORTS-11 Hangar Way, Watsonville, CA 95076 - www.mugnaini.com - mugnaini@mugnaini.com
Toll Free: 888 887-7206 - Phone: 831 761 1767 - Fax 831 728-5570