

CLEARANCES:

Install the oven with a minimum 1 inch clearance on sides and back to combustible construction. Consult the manual for enclosure instructions.

VENTING:

The oven can be vented in two methods:
 1) Direct vent using 8 inch chimney pipe listed to UL 103 HT and installed per UL 737.
 2) Indirect vent using a Type 1 hood system installed per UL 2162.

GRANITE MANTLE:

Stainless steel shelf bolts to oven. 1" thick granite provided by installer.

WEIGHT: 3700 lbs.

UTILITIES:

No electricity or gas required.

NOTE:

The oven should be installed in accordance with all relevant local and national codes and in a manner acceptable to the authority having jurisdiction.

Progressive changes in technology and product development may necessitate changes to specifications without notice.

TOP VIEW

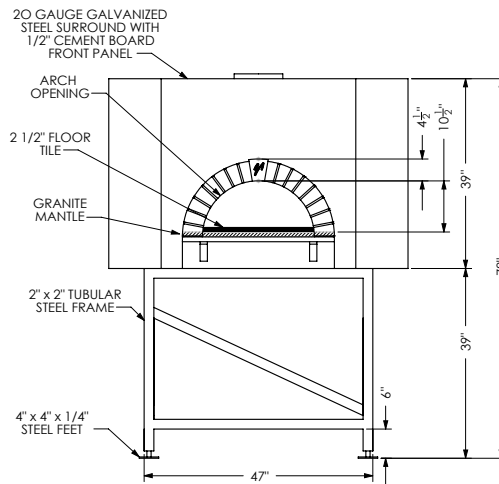
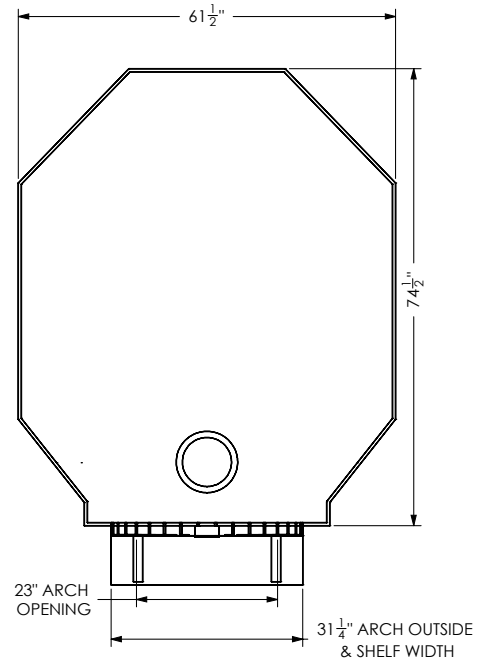

FRONT VIEW

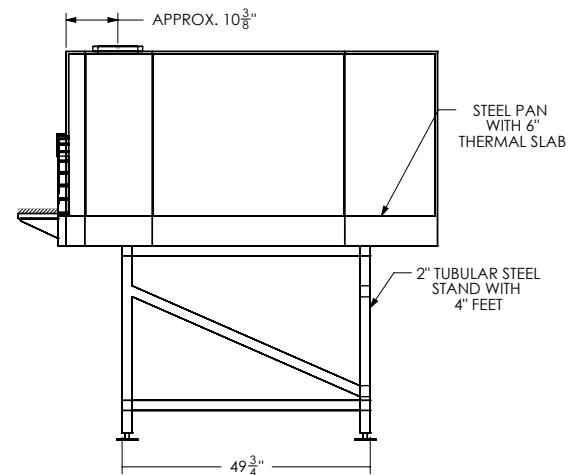

SIDE VIEW



UL 2162 and UL 737

ANSI/NSF-4

© COPYRIGHT 2011, Mugnaini Imports, Inc.
 May not be used without permission of copyright holder.



Mugnaini Imports, Inc.

11 Hangar Way, Watsonville CA 95076

888.887.7206 | 831.761.1767 | Fax: 831.728.5570

www.mugnaini.com | mugnaini@mugnaini.com