

MUGNAINI®

PRIMA 100 FORNO AL FRESCO FLAT TOP ENCLOSURE

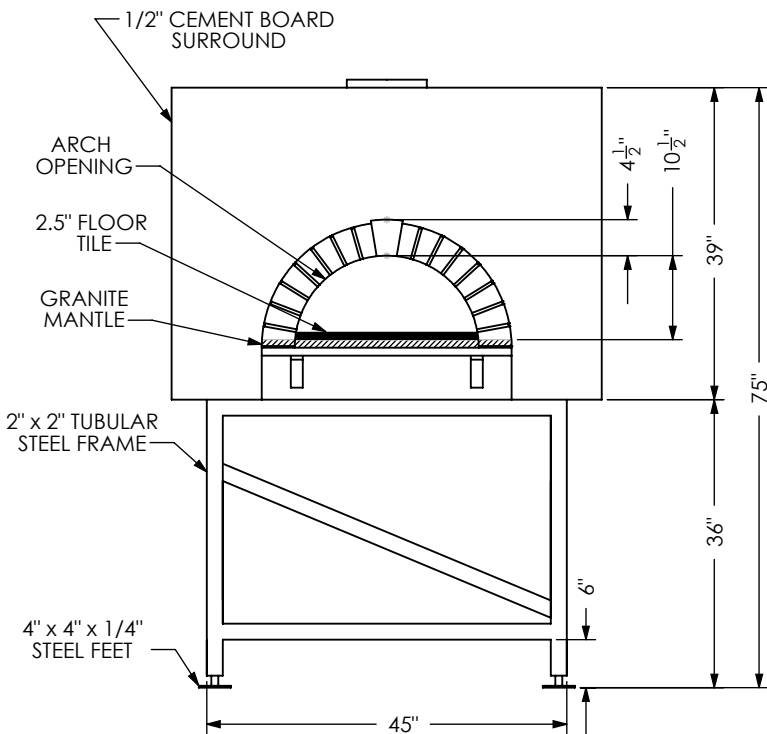
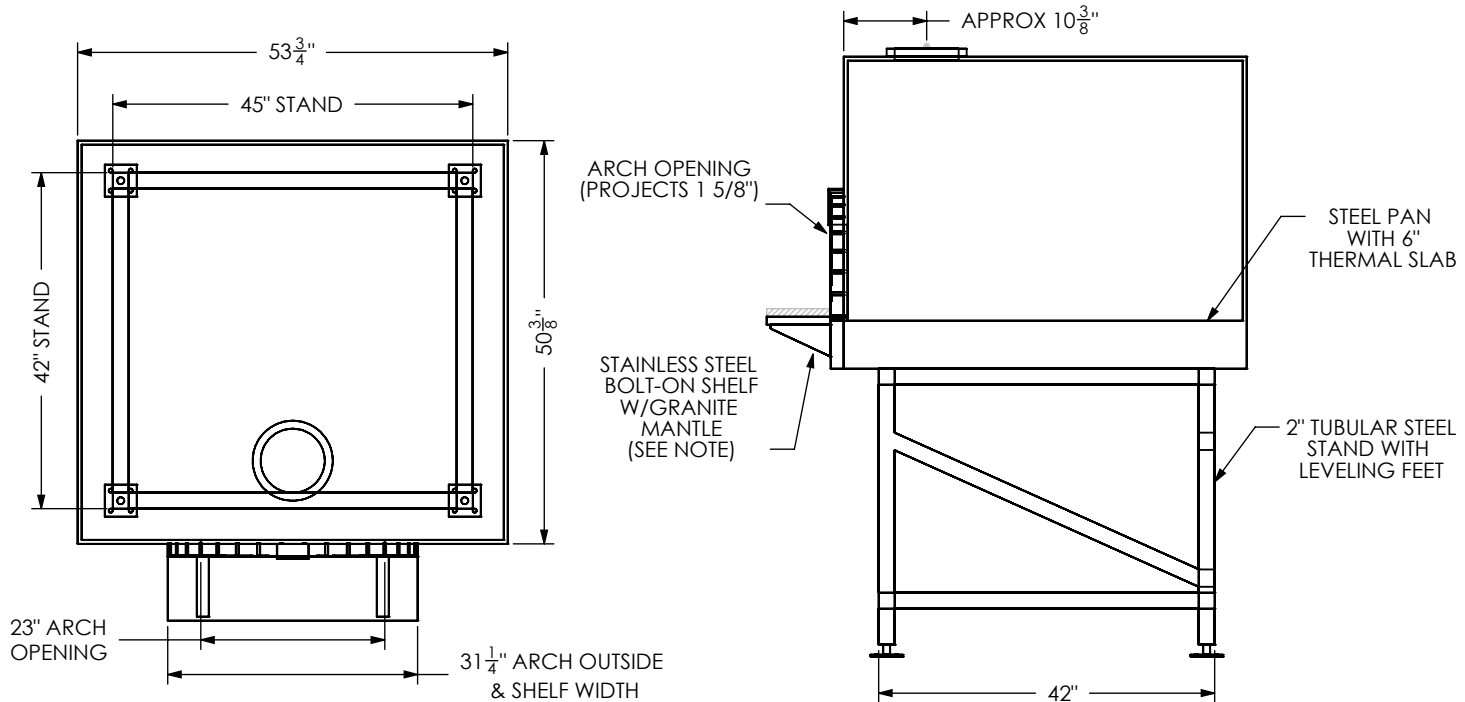

NOTES:

CLEARANCES

The oven shall be installed a minimum of 2" away from combustible material from back wall to oven and side wall to oven. You may bridge the gap between any wood framing and the oven by using metal framing with concrete board or masonry.

WEIGHT

3260#

VENTING

The oven is direct vented with an 8" chimney pipe listed to the UL 103 HT standard. The chimney starts with an anchor plate and requires a minimum rise of 36" for the oven to properly draft. The Chimney must terminate to a UL listed spark arrestor installed 2' taller than any structure within a 10' radius.

Granite Mantle

Stainless steel shelf bolts to oven. 1" thick Granite provided by installer. A custom shelf may be provided by others.

UTILITIES

No electricity or gas required.

LISTINGS

Mugnaini Wood-fired Ovens have been tested and comply with the UL-737 safety standard.

Progressive changes in technology and product development may necessitate changes to specifications without notice.

DRAWINGS NOT TO SCALE

