



ITALY'S ORIGINAL PIZZA OVEN

FACTORY ASSEMBLED

MODEL: PICCOLO 80PA

BUILT-IN ENCLOSURE

RESIDENTIAL WOOD FIRED OVEN

**CLEARANCES:**

The oven shall be installed a minimum of 2" away from combustible material from back wall to oven and side wall to oven. You may bridge the gap between any wood framing and the oven by using metal framing with concrete board or masonry.

**VENTING:**

The oven is direct vented with a 6" chimney pipe listed to the UL 103 HT standard. The chimney starts with an anchor plate and requires a minimum rise of 36" for the oven to properly draft. The Chimney must terminate to a UL listed spark arrestor installed 2' taller than any structure within a 10' radius.

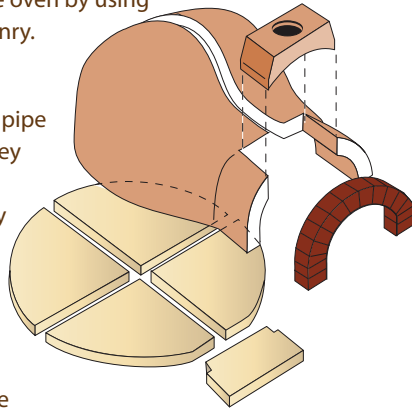

**SHELF:**

Stainless steel shelf bolts to oven. Shelf to be covered with non-combustible material provided by installer.

**UTILITIES:**

No electricity or gas required.

**FLOOR HEIGHT: 45"**

**WEIGHT: 1250 lb.**

**NOTE:**

The oven should be installed in accordance with all relevant local and national codes and in a manner acceptable to the authority having jurisdiction.

Progressive changes in technology and product development may necessitate changes to specifications without notice.



© COPYRIGHT 2011, Mugnaini Imports, Inc. May not be used without permission of copyright holder.

TOP VIEW

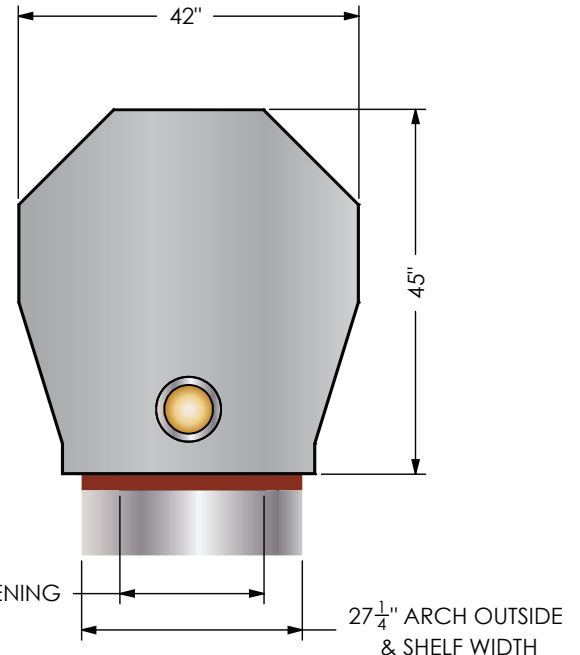

OVEN COMPONENTS

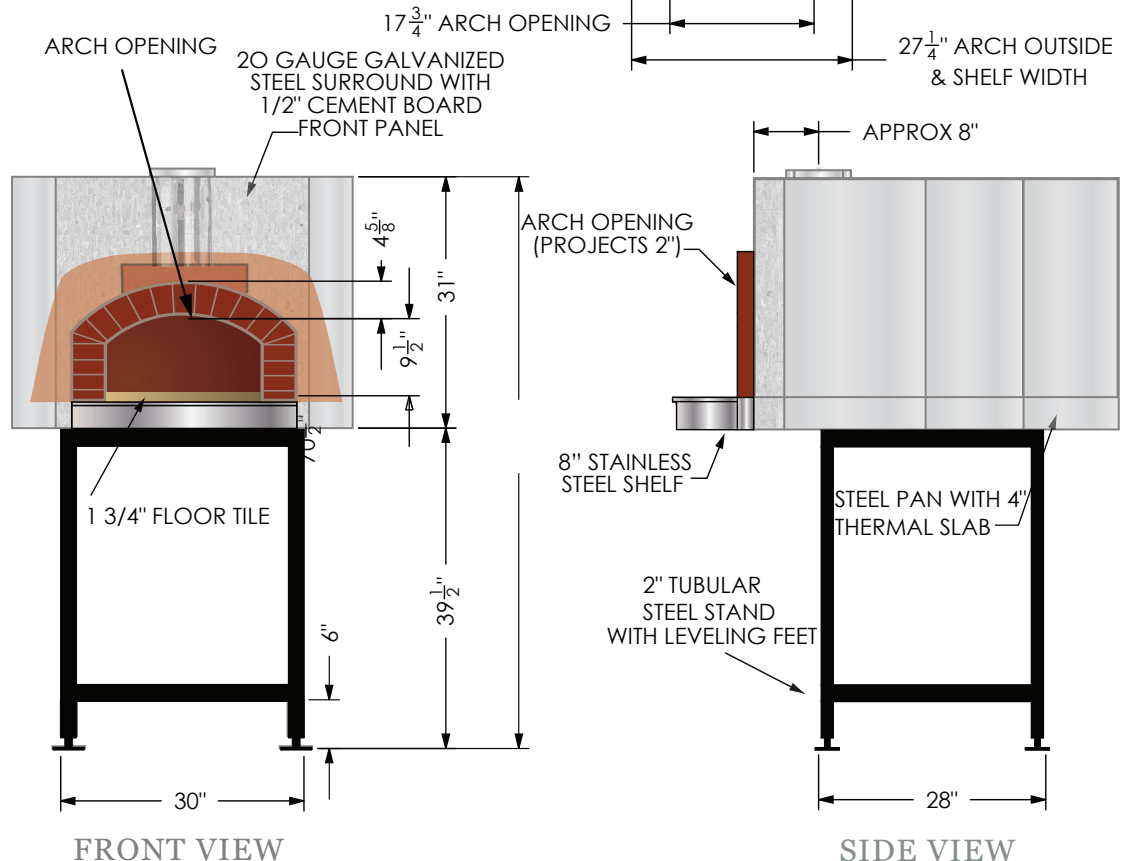

FRONT VIEW

SIDE VIEW



Mugnaini Imports, Inc.

11 Hangar Way, Watsonville CA 95076

888.887.7206 | 831.761.1767 | Fax: 831.728.5570

www.mugnaini.com | mugnaini@mugnaini.com